

# CF Series

## Cylindrical EMI Suppression Ferrites

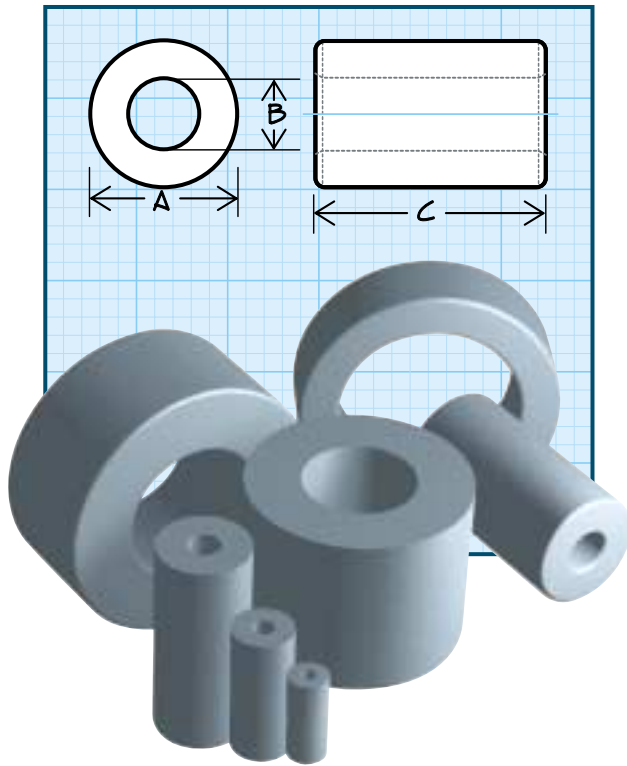

API's Cylindrical EMI Suppression ferrites provide a cost effective means of reducing common and differential mode EMI. Used to suppress common mode EMI on the internal and external cable assemblies of electronic equipment.

Select a ferrite with an inner diameter most closely matching the outer diameter of the wires to be filtered.

### Features

- Wide range of sizes with inner diameters from 1.5 mm (0.059 inches) to 23 mm (0.905 inches)
- Precision formed smooth surfaces prevent damage to wire insulation
- Available in API-1 and API-2 material. See page 121.
- Custom designs available

### Applications

- Internal and external computer data and power cables.

**\*\*Note – Impedance Testing** Impedance is typical, measurement using HP4191A. For CF1-4\*1.5\*10 through CF2-4.6\*1.85\*6, based on 1/2 turn (4.0") 32 AWG wire. For CF1-7.35\*5.1\*10 and above, based on 1/2 turn (4.0") 19 AWG wire.

PART NUMBER	IMPEDANCE**			DIMENSION A		DIMENSION B		DIMENSION C	
	@ 25 MHz (Min.)	@ 100 MHz (Typ.)	@ 300 MHz (Typ.)	INCHES	mm	INCHES	mm	INCHES	mm
CF1-4*1.5*10	50	135	300	0.157±.007	4.0±0.2	0.059±.005	1.5±0.15	0.393±.015	10.0±0.4
CF2-4*1.5*10	55	116	269	0.157±.007	4.0±0.2	0.059±.005	1.5±0.15	0.393±.015	10.0±0.4
CF1-4*2*10	40	102	282	0.157±.007	4.0±0.2	0.078±.007	2.0±0.2	0.393±.015	10.0±0.4
CF2-4*2*10	40	86	255	0.157±.007	4.0±0.2	0.078±.007	2.0±0.2	0.393±.015	10.0±0.4
CF1-4.6*1.85*6	35	89	261	0.181±.007	4.6±0.2	0.072±.007	1.85±0.2	0.236±.011	6.0±0.3
CF2-4.6*1.85*6	35	77	237	0.181±.007	4.6±0.2	0.072±.007	1.85±0.2	0.236±.011	6.0±0.3
CF1-7.35*5.1*10	23	68	217	0.289±.011	7.35±0.3	0.200±.007	5.1±0.2	0.393±.015	10.0±0.4
CF2-7.35*5.1*10	23	63	214	0.289±.011	7.35±0.3	0.200±.007	5.1±0.2	0.393±.015	10.0±0.4
CF1-9.5*4.8*20	70	171	263	0.374±.011	9.5±0.3	0.188±.007	4.8±0.2	0.787±.023	20.0±0.6
CF2-9.5*4.8*20	80	142	251	0.374±.011	9.5±0.3	0.188±.007	4.8±0.2	0.787±.023	20.0±0.6
CF1-10.5*5.5*20	65	161	273	0.413±.015	10.5±0.4	0.216±.007	5.5±0.2	0.787±.023	20.0±0.6
CF2-10.5*5.5*20	70	134	261	0.413±.015	10.5±0.4	0.216±.007	5.5±0.2	0.787±.023	20.0±0.6
CF1-12*7.3*15	40	107	273	0.472±.019	12.0±0.5	0.287±.011	7.3±0.3	0.590±.019	15.0±0.5
CF2-12*7.3*15	40	89	242	0.472±.019	12.0±0.5	0.287±.011	7.3±0.3	0.590±.019	15.0±0.5
CF1-14.2*6.35*28.5	115	280	302	0.559±.019	14.2±0.5	0.250±.011	6.35±0.3	1.122±.031	28.5±0.8
CF2-14.2*6.35*28.5	125	230	210	0.559±.019	14.2±0.5	0.250±.011	6.35±0.3	1.122±.031	28.5±0.8
CF1-16*9*17	50	130	281	0.629±.019	16.0±0.5	0.354±.011	9.0±0.3	0.669±.023	17.0±0.6
CF2-16*9*17	55	109	257	0.629±.019	16.0±0.5	0.354±.011	9.0±0.3	0.669±.023	17.0±0.6
CF1-17.5*9.5*28.5	95	217	310	0.688±.023	17.5±0.6	0.374±.011	9.5±0.3	1.122±.031	28.5±0.8
CF2-17.5*9.5*28.5	95	172	296	0.688±.023	17.5±0.6	0.374±.011	9.5±0.3	1.122±.031	28.5±0.8
CF1-21*13.2*21	55	136	309	0.826±.023	21.0±0.6	0.519±.019	13.2±0.5	0.826±.023	21.0±0.6
CF2-21*13.2*21	55	115	305	0.826±.023	21.0±0.6	0.519±.019	13.2±0.5	0.826±.023	21.0±0.6
CF1-26*13*28.5	100	235	325	1.023±.027	26.0±0.7	0.511±.019	13.0±0.5	1.122±.031	28.5±0.8
CF2-26*13*28.5	110	198	316	1.023±.027	26.0±0.7	0.511±.019	13.0±0.5	1.122±.031	28.5±0.8
CF1-28*15.6*7.5	28	85	313	1.102±.031	28.0±0.8	0.614±.019	15.6±0.5	0.295±.011	7.50±0.3
CF2-28*15.6*7.5	28	76	286	1.102±.031	28.0±0.8	0.614±.019	15.6±0.5	0.295±.011	7.50±0.3
CF1-31*19*10	30	91	232	1.220±.031	31.0±0.8	0.748±.023	19.0±0.6	0.393±.015	10.0±0.4
CF2-31*19*10	30	83	320	1.220±.031	31.0±0.8	0.748±.023	19.0±0.6	0.393±.015	10.0±0.4
CF1-36*23*15	40	113	384	1.417±.031	36.0±0.8	0.905±.023	23.0±0.6	0.590±.019	15.0±0.5
CF2-36*23*15	40	101	369	1.417±.031	36.0±0.8	0.905±.023	23.0±0.6	0.590±.019	15.0±0.5

# CF Series

## Cylindrical EMI Suppression Ferrites

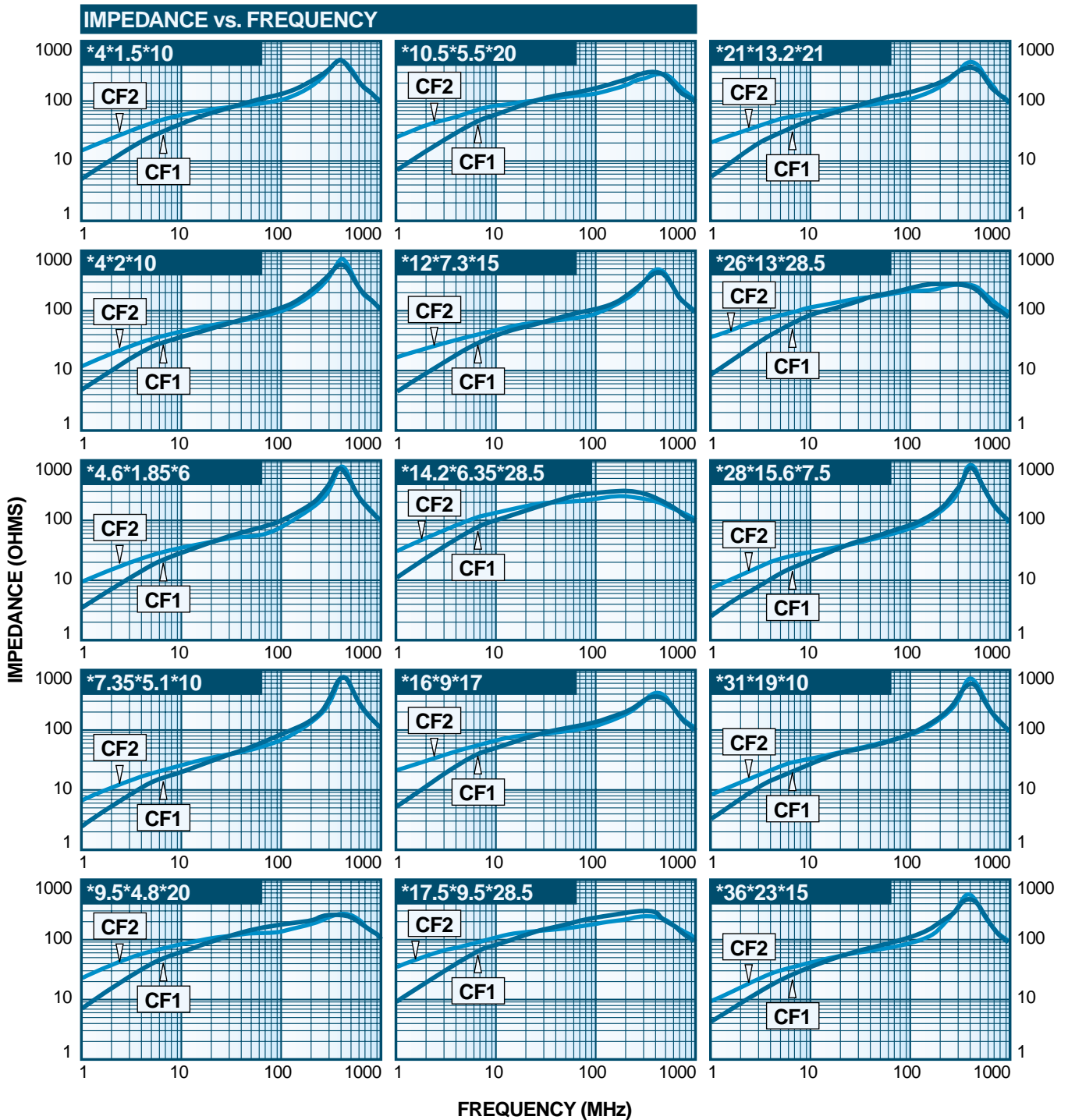

For more detailed graphs, contact factory